

# BRAÜNIGER FLUGELECTRONIC



## COMPETINO Manual Vers.1.21

Grey marked texts show the differences of this version compared to the last one

Bräuniger GmbH  
Dr. Karl Slevogt Str.5 D-82362 Weilheim

+49 881 64750 [info@brauniger.com](mailto:info@brauniger.com) [www.brauniger.com](http://www.brauniger.com)

Feb. 2009

# 1 Operation

## 1.1 Turning the Unit On and Off

The unit is switched on by pressing the  key. You must confirm the switch on, by pressing the “Enter” key.

To switch it off, you need to press the same key for three seconds. The unit will then display the question ‘switch off?? Press Enter’ Confirm by pressing “Enter”. After a long flight with short record intervals the calculation of the digital signature can take up to one or two minutes. Please wait until this process is finished. Press O/ESC key again to turn off the unit.

## 1.2 Keypad

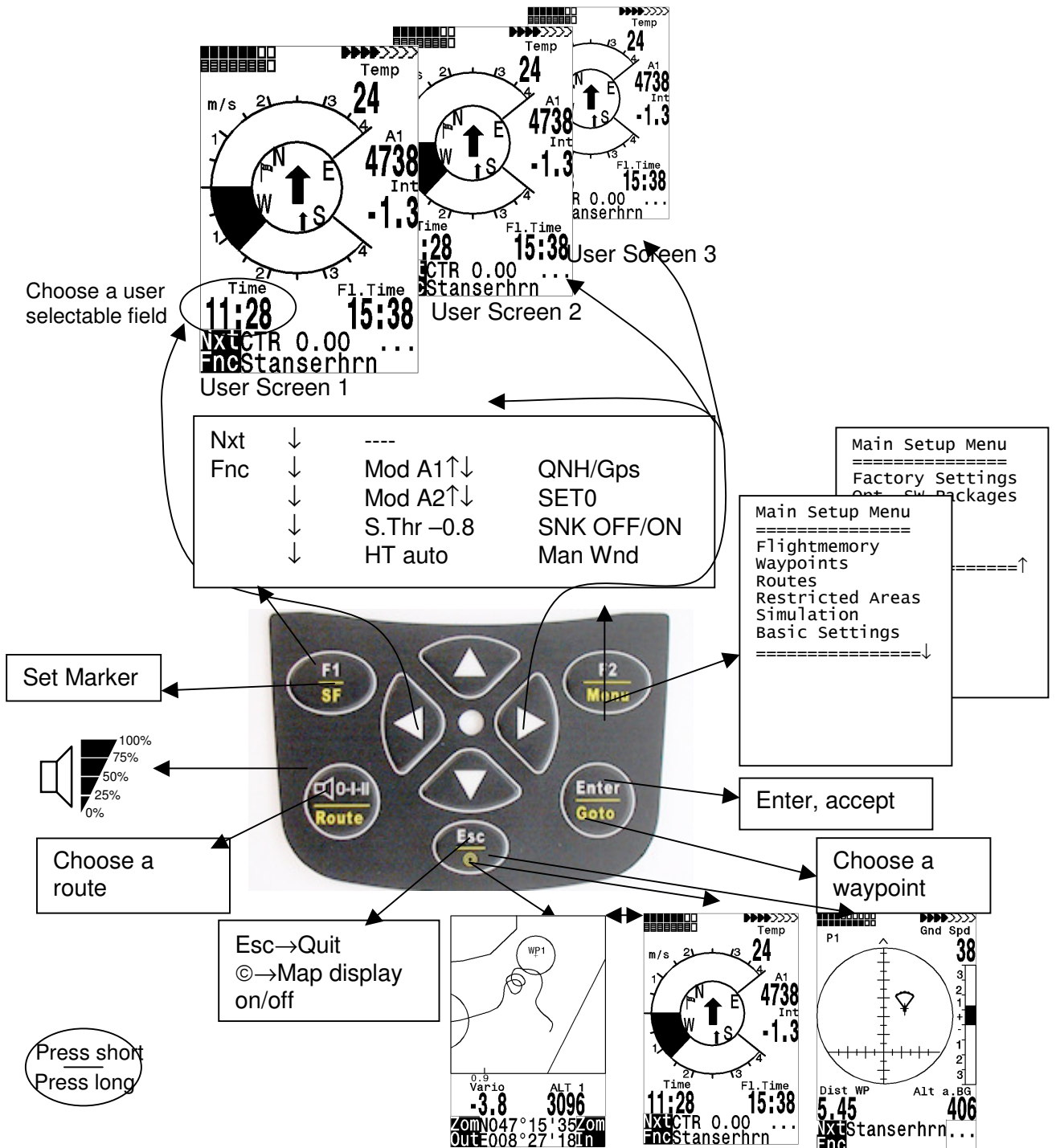

### 1.3 Main Screen

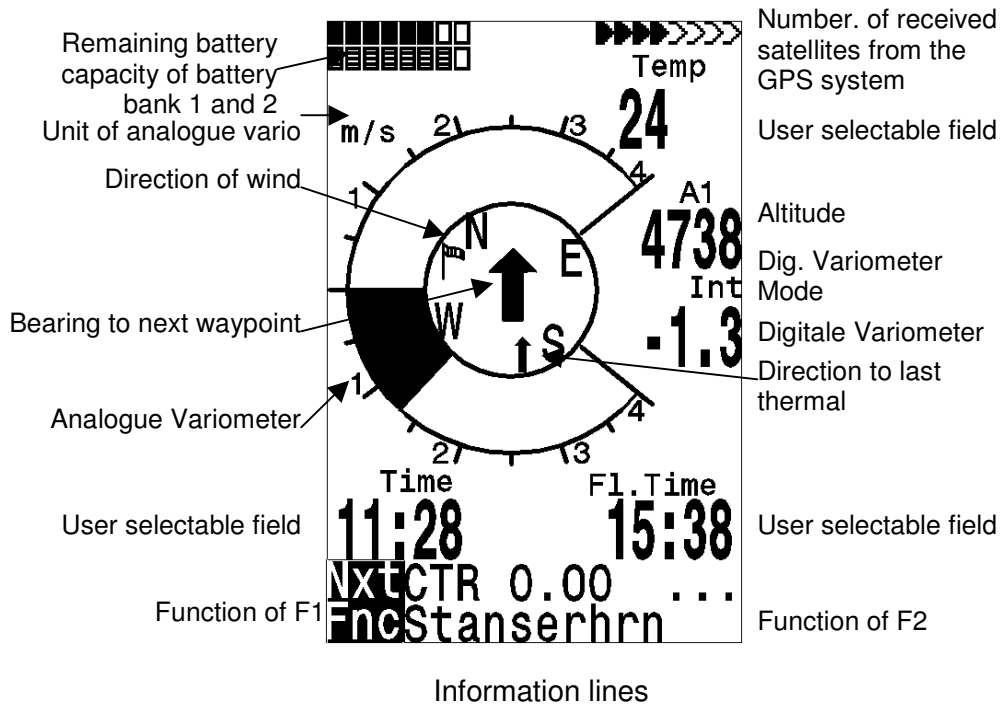

### 1.4 Map Screen

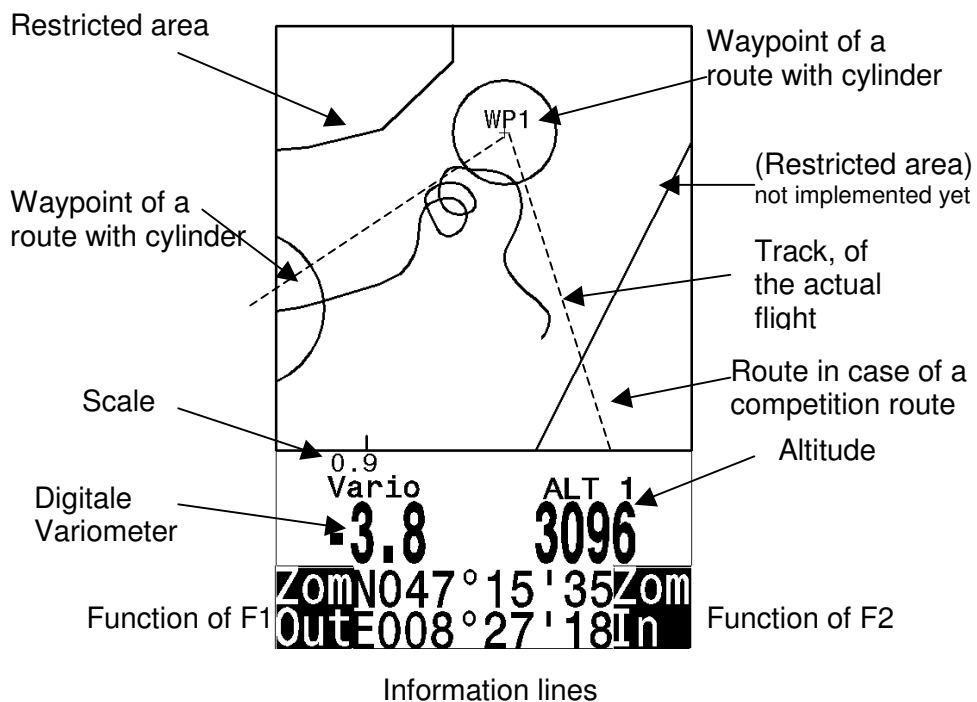

The flight route of saved flights can also be shown on the display and viewed. Flight Analysis is reached by pressing F1 to display the function Show Map. The screen-optimized flight route is shown on the display. (North is located at the top) Additionally, stored waypoints are plotted with a cross and name. The map scale is displayed too.

The graph can now be changed as follows:

**F2: Zoom in:** The map scale is gradually increased to approx. 0.5-1.0km. Thus, individual circles during a climbing period are clearly recognizable (This is dependent on the set recording interval).

**F1: Zoom out:** The map scale is gradually decreased until the screen display is optimized.

**Enter:** From each graph back again to the screen optimized graph.

**ESC:** Back to the main setup menu. All other keys cause the track in the current selection to be redrawn.

**Arrow keys: Pan:** With these keys, the plotted area can be shifted up, down, left and right. This function is only enabled in flight memory mode. During flight, the actual position is in the center of the map. If the position reaches a border, the map pans automatic.

**Note:** As the picture takes a few seconds to appear, depending on the amount of data, Wait and Ready appear on the status line as user information; if a zoom or pan key is touched during the process then it will be broken off and will start over again with new values. You can thus obtain the desired graph quickly. Even past flights can be graphed as long as they are still saved.

During the flight, touching the ESC key briefly will bring you a real-time track and map display. Vario and height appear digitally under the map. For competition routes, the cylinder of the active waypoint, WP names, and a thin dotted line to the next WP are also displayed. During the flight the Zoom In/Out functions are accessible.

## 1.5 Final glide screen

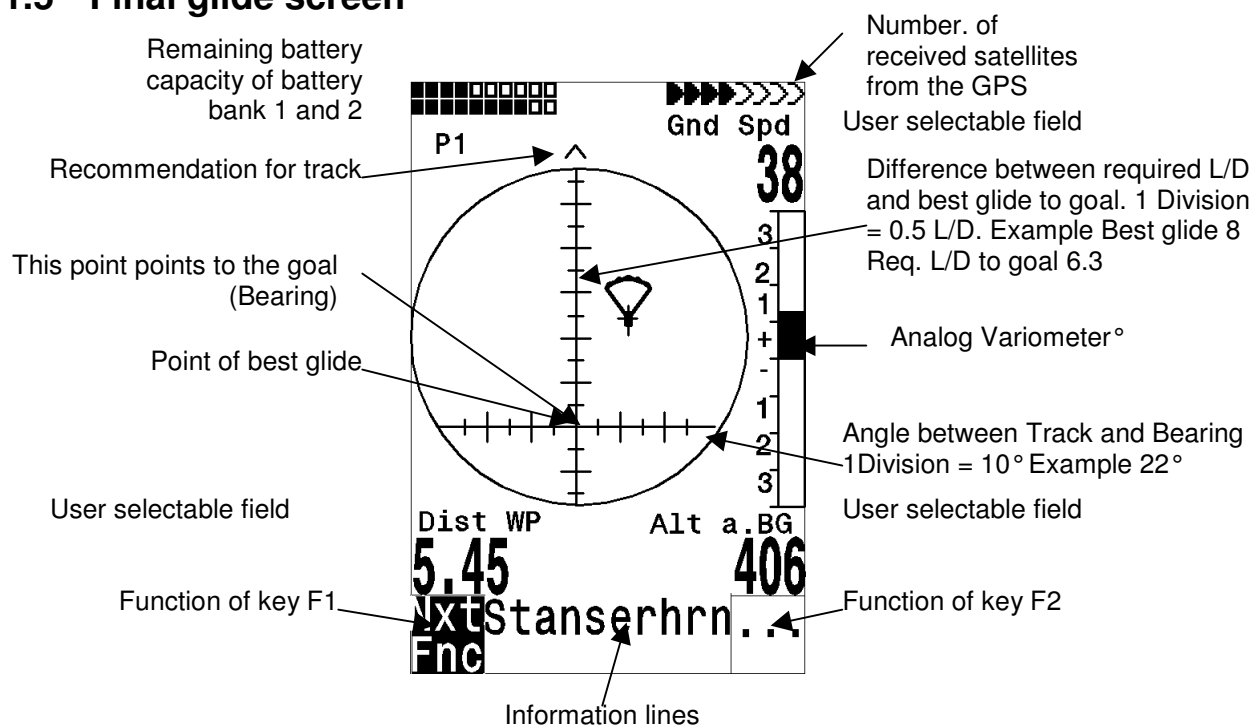

The final approach - screen serves as an assistance for the final glide. It is less suitable for the normal flight. It will be normally activated in the last thermal before the goal. The horizontal scale shows the deviation between current track and bearing (the direction to the goal). 1 division line is 10°, between two large lines is 20°. The vertical scale shows the deviation of the necessary lift/drag ratio to the goal by the number of best glide of the aircraft, which will be set in the basic Settings. A division line corresponds to 0,5 lift/drag ratio. Between two large division lines is 1 lift/drag ratio.

The example shows an aircraft with lift/drag ratio 8. The necessary lift/drag ratio to the goal is 6.3. The aircraft symbol is around 2.3 units above the point of best glide.

The strategy is, to hold the symbol in the crossover during the final glide. In order to hold something reserve, experienced pilots will fly rather above the point of best gliding. During thermalling the symbol remains in the center. As long as the deviation is larger than approx. 20 lift/drag ratios, the symbol appears grey in the center. Below that margin, the symbol disappears to approximately 20 lift/drag ratios deviation. With approximately 6 lift/drag ratio it appears then again from down in the window. If it comes upward over the delimitation, it appears again grey.

A small arrow appears ^ above with the increase as a heading assistance, if track and bearing are within +/- 10°. When sinking the arrows < ^ > indicate a recommendation, where one should hold. If the symbol leaves the range of approximately plus minus 60°, the symbol is grey again. One should switch then with the Esc key to the Vario screen, in order to see the compass with the direction markers.

## 1.6 Main Setup Menu

Flightmemory	List of the flights in memory.
Waypoints	List of the waypoints with the possibility to edit waypoints and coordinates
Routes	List of the routes with the possibility to edit
Restricted Areas	List of the restricted areas with the possibility to edit
Simulation	Here you can simulate most of the important flight parameters.
Basic Settings	Here you can change the most important parameters
Factory Settings	Only for service
Opt. SW-Packages	Here you can enable SW packages you bought from Brauniger.

## 1.7 Basic Settings

A series of settings permit the unit to be programmed according to the user's wishes. Every pilot can realize his/her own ideas. If too much information bogs you down and causes confusion, it is always possible to reset the unit at Basic Settings/ Init EEPROM, which are the manufacturer's tested basic settings. You are basically starting again.

**But please note!** All WP and routes will be a deleted too. As a minimum, settings possible and default values set will be shown at the setting points. Should these values be changed, you move to the change mode by pressing Enter. The value to be changed will blink and can be modified with the help of the ▼ and ▲ keys. Pressing the Enter key confirms the new value. Pressing the ESC key recalls the previous setting.

Term	Meaning	Referen ce	Factory Setting
Display contrast	Range 0 ... 100 %		70 %
Record-Interval	Time interval per recorded (track log) point		10 Sec
Recording mode	Autom. or manual flight recording		Aut.
Digital Variomode	Averager ; Averager time delay		1 sec 30 sec
Vario tone	Frequency of Climb and Sink tone, Pitch Modulation, Acoustic Integrator		1200 Hz ; 700 Hz Mod = 5 ; Pi=3; 8
Battery type	Type of battery used. This has an influence on the Bargraph and the switching thresholds		Alcaline

## COMPETINO technical manual

Audio threshold	Fine tuning of climbing tone max 20 cm		2 cm/sec
Sink tone thres.	Activation point of sink tone		0,8 m/s (ft/m)
L.thermal thres	Threshold for the last thermal		0.5 to 3.0 m/s
Vario/Spd delay	Response time delay for Analogue Vario and Speed		12 ( » 1,2 sec)
Best L/D	Best glide ratio with according speed		
Stallspeed	Use of stall alarm and altitude limit		0 km/h (mph)
Spd corr. vane	Windwheel 70 ... 150 % correction		100 %
Units	Meter or feet; Km/h or mph or knots Temp.: In Grd C or Grd F		m ; km/h ; Grd C
Coordinate Format *	dd°mm,mmm or dd,dddd or dd°mm'ss" UTM ; Suisse Grid #		dd,mm,mmm
Time Date Year	Time difference to UTC		Present
Pilotname	Pilot name entry; max 25 letters		not set
Glider type	Name of glider for OLC		not set
Glider ID	Glider registration for OLC		not set
Del all records	Deletion of flight memory (all records)		no
Del all WP& Rts	Deletion of all WPs and Routes		no
Init EEPROM	Back to factory settings		No
Init CTRs	Reorganization of the memory		

Attention: The deletion of waypoints, routes or records needs a few seconds to perform. Please wait until the confirmation shows up.

### 1.8 User selectable fields

The main screen as well as the final approach screen can show up to three pages with user selectable fields. The pages can be selected with the ► key and the page number is displayed under the battery status as P1 to P3.

Alt a. BG	Safety height above the best glide path* (Not available in first SW release 1.10 and 1.11)
FL (ft)	Flight Level not adjustable by the user
Airspeed	Speed measured with the vane wheel, true air speed or calculated airspeed
Alt a. GI	Calculated height above goal, calculated for a route, including Windspeed an direction*
Dist GI	Distance to goal calculated along a route*
WindSpd	Wind strength*
Vario	The digital vario as userfield for the final glide screen
A1	The altitude A1 as userfield for the final glide screen
Dst Toff	Distance to start or flight recognition (acceptance)
Dist Cyl	Distance to the radius of a waypoint cylinder in case of a competition route
Dist to WP	Distance to chosen destination (waypoint)*
Fl.Time	Flight time since take off
GND speed	ground speed*(=GS)
Time	Time
Bearing	Direction to chosen destination*
Wind Spd	The calculated Windspeed, derived from a circle.
Spd-Diff	Wind component (ground speed minus true airspeed)*
Track	Flight direction (course)*
Temp	Internal temperature

Alt 2	Reference height (if desired can be set at 0)
Alt 3	Cumulated gained height
QNH hPa	Air pressure in hector-Pascal
L/D gnd	Actual L/D over ground (=Ground Speed/Sink)*
L/D air	Actual L/D in air, only available with vane wheel connected
L/D req	L/D required to reach a WP*
L/D r. Gl	L/D required to goal over the next waypoints
Dist to^	Distance to last thermal*
RaceStart	Countdown timer to the start gate time. Invers after start.

\* Only active when the GPS receiver is switched on

## 1.9 Battery management

Two bar graph scales indicate the capacity of the batteries. The Brauniger Competino has 2 banks with 2 batteries each. Bank 1 must always be equipped. Bank 2 can remain free. However, we recommend to equip bank 2 also. As soon as the first bank is used up, the instrument switches automatically to the second bank. If the second bank is not yet used up, and bank 1 is equipped with new batteries, the instrument switches to the first bank again. After a long flight we recommend to insert the partly used batteries of the bank 2 into bank 1 and to equip bank 2 with new batteries. Thus it is ensured that the instrument can use up the batteries always completely, without the danger of having empty batteries during a flight. Before S/N 5500 the two banks in the battery compartment where changed.

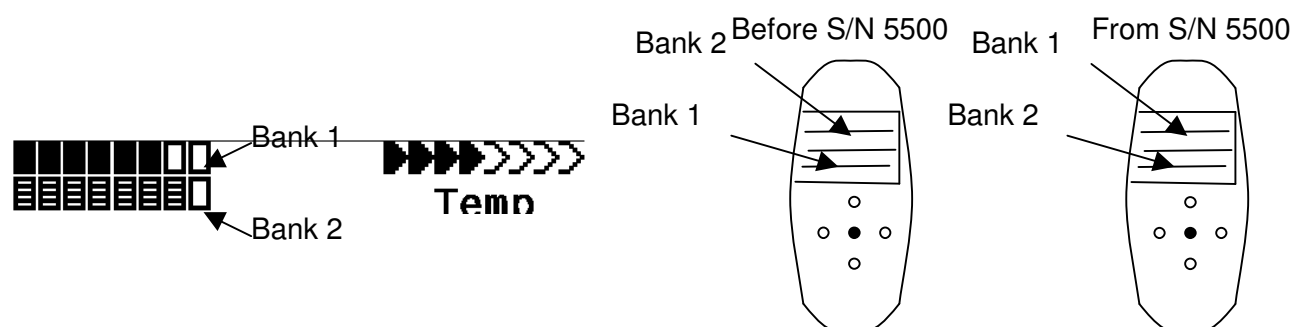

The following battery types could be used

2 pieces per bank Alkaline High Power Batteries 1.5 Size AA. Estimated life time  $2 * 13h = 26h$  together (recommended types: VARTA or Duracell)

2 pieces per bank NiMH Accu 2100mAh, 1.2V Size AA. Estimated life time  $2 * 11h = 22h$  together. The bargraph shows only the actual battery voltage, not the capacity.

We don't recommend NiCd Accu because they have clearly smaller capacities and are not pollution free. The battery thresholds are optimized for NiMH Accus.

Please dispose of the batteries properly.

The estimated life time bases on normal temperature conditions. If the batteries are hotter or colder they have another capacity, and therefore another life time. The Bargraph shows only the actual battery voltage, not the capacity.

The inserted battery type is not recognized automatically. Because the battery types have different voltages and a different temperature behaviour, the battery type must be entered into the basic Settings. If the wrong battery type is specified, it is possible that the instrument switches off during switching between bank 1 and bank 2.

## 1.10 Data Exchange Via PC

The Competino's basic equipment includes a data cable for a serial PC interface (9 pol Sub D plug). Data transfer can occur in both directions. The connection occurs with: 57.600 baud; 1 startbit; 8 databit; 1 stopbit; no parity, Xon/Xoff

The following can be read via this RS232 interface:

Serial numbers and pilot names  
Waypoint list  
Route list  
A selected flight (track)  
CTRs, restricted areas

The following can be uploaded to the Competino:  
Waypoints and routes

**Important:** the unit must first be switched on before plugging in the connection cable to the unit and the computer.

Before you transfer the waypoints and route data switch the Competino to the Setup Menu. You should make sure that the waypoints show up in the unit's waypoint list before you transfer a route from your computer.

If you wish to download flight data, switch the unit to the Flight memory mode, and display the desired flight on the Flight Analysis screen before transferring it to your computer. There are a number of PC programs on the market that allow communication with the Competino. We recommend the program Flychart which you can download from the Brauniger Website [www.Brauniger.com](http://www.Brauniger.com)

Other programs that permit data transfer with the Competino:

Trackview (Freeware)	Daniel Zuppinger (for OLC und CCC) <a href="http://www.softtoys.com/">www.softtoys.com/</a>
Compe-GPS	<a href="http://www.compegps.com">www.compegps.com</a>
Seeyou	Program well liked by sailplane pilots <a href="http://www.seeyou.ws">www.seeyou.ws</a>
Maxpunkte	Free program from DHV for reading flight data for evaluation and submission to OLC. <a href="http://www.flugplatz-beilrode.de/maxpunkte/download.html">http://www.flugplatz-beilrode.de/maxpunkte/download.html</a>
GPSDump	Stein Sorensen . A simple program for IGC File dump. <a href="http://www.multinett.no/~stein.sorensen/">http://www.multinett.no/~stein.sorensen/</a>

## 1.11 Transferring New Firmware to the Competino

As is the case with many other new developments, particularly during the introduction phase, improvements or feature enhancements may be expected. Periodically Brauniger will post firmware updates at [www.Brauniger.com](http://www.Brauniger.com), which can be downloaded by the user free of charge, and then uploaded to the Competino.

To be able to write to the Competino's flash memory with a PC, it is necessary to use a compressed file named "Flasher.exe" that is available in zipped form [flasher.zip](#). In addition, the actual firmware to be uploaded must be obtained. It is called "Competino vxxx.moc" which corresponds to the version X.XX. Both of these are available from the download page at [www.Brauniger.com](http://www.Brauniger.com)

We recommend that you store all the related files in a separate subdirectory. (e.g. `c:\programs\BraunigerFlasher\`). After decompressing the ZIP file a number of files are created. Double clicking on the file "flasher.exe" starts the program. Under "Setup", the serial port (COM1 or COM2) can be chosen. You select the file to be transferred with the extension ".moc" by pressing on the "Start" key. The data transfer starts automatically. The numbers shown on the right side are the answers of the instrument.

Sometimes the Flasher will give an error. In this case, the cable must be unplugged, and the Competino turned off before making another attempt to flash the memory.

**Important:** Contrary to the instructions for data transfer of waypoints or routes, be sure that the Competino is turned off when plugging the cable into the computer and the Competino.

**Important:** Never leave the PC cable hooked up to the unit when it is turned off. If this is done energy is consumed, and the battery can be drained.

## 2 Technical Data

Measurements:	165 x 73 x 38 mm
Weight:	286 grams (with 4 Alkaline batteries, without harness)
Electrical supply:	2 or 4 alkaline batteries AA or Nickel metal hydride accumulator 2 Ah; 1.2V
Battery life:	> 30 hrs with 4 alkaline batteries
Altimeter:	Max. 8000 m; 1 m (3 ft) steps
Variometer:	Analog +/-8 m/s; (1600 ft/m); 0.2m/s (20 ft/m) steps
Variometer	Digital +/-70m/s; (14.000 ft/m); 0.1m/s (20 ft/m) steps
Speed (vane wheel)	Digital 0 - 120km/h (or mph or kts)
Waypoints:	200 WP
Routes:	20 routes with max. 30 WP in each
Restricted areas	20 CTR's free, 150 CTRs due to costs
Max. memory time:	55 hrs flying time at 10 sec intervals
Number of track log points:	24 000
Number of registered flights:	100

Data memory and transfer according to the IGC format

Screen resolution 240 x 160 pixel (=1/8 VGA)

Operating temperature -15...45 °C

Brackets for hang-gliders or paragliders are available.

The technical details may be altered without notification. Software upgrades can be made by downloading the latest firmware version from our homepage

## 3 Guarantee and liability

Our instruments carry a 24-month guarantee. However, physical damage such as a broken casing or glass breakage as well as damage resulting from water landings are excluded from this guarantee. Brauniger can accept no liability for faults arising from any abuse or unapproved use of your instruments.

### WARNING

In very rare cases it can happen that a flight instrument does not provide any data at all or the data is incorrect. Brauniger GmbH will not be held responsible for accepting any damage claims arising from a malfunctioning unit. Responsibility for ensuring the safe execution of his/her flights lies with the pilot alone.

## 4 Contents

1	Operation .....	2
1.1	Turning the Unit On and Off .....	2
1.2	Keypad .....	2
1.3	Main Screen .....	3
1.4	Map Screen .....	3
1.5	Final glide screen .....	4
1.6	Main Setup Menu .....	5
1.7	Basic Settings.....	5
1.8	User selectable fields .....	6
1.9	Battery management .....	7
1.10	Data Exchange Via PC.....	7
1.11	Transferring New Firmware to the Competino .....	8
2	Technical Data .....	9
3	Guarantee and liability .....	9
4	Contents.....	10
5	Analog Vario .....	11
5.1	Altimeter and Air Pressure.....	11
5.2	Acoustics and Volume Level .....	11
5.3	Digital Vario .....	13
6	Speed.....	13
6.1	Stall Alarm .....	14
7	GPS Functions.....	14
7.1	Assessment of Reception Quality.....	14
7.2	Compass and Flight Direction .....	14
7.3	Track and Bearing .....	15
7.4	Groundspeed.....	15
7.5	Glide Ratio (=L/D Ratio) .....	15
7.6	Head, Cross and Tail Winds; the Wind Component .....	16
7.7	Wind Direction and Strength.....	17
7.8	Waypoints and Co-ordinates .....	17
7.8.1	Waypoints - Alter, Delete, or Add.....	18
7.8.2	Current Coordinate Indicator.....	18
7.8.3	Distance to Waypoint.....	19
7.8.4	Distance to goal.....	19
7.8.5	Distance to the waypoint cylinder radius.....	19
7.8.6	Distance to Takeoff.....	19
7.8.7	Saving the Current Position .....	19
7.9	Goto—Function .....	20
7.10	Flying Routes .....	20
7.11	Routes Set - Delete - Alter.....	22
7.11.1	Setting a New Route.....	22
7.11.2	Altering a Route: .....	22
7.11.3	Deleting a Route: .....	23
7.11.4	Changing a route into Competition Route:.....	23
7.12	The Competition Route.....	23
7.12.1	Competition - Route Set - Alter - Delete.....	23
7.13	Flying a competition route .....	23
7.14	Final glide screen and final glide calculations.....	26
7.15	Relocating Thermals.....	27
7.16	Restricted Area.....	27
8	Flight Memory and Flight Analysis .....	29
9	User selectable fields.....	30
9.1	Temperature.....	30
9.2	Time and Date.....	30
9.3	Flight time.....	31
10	Other functions.....	31
10.1	Simulation.....	31
10.2	Battery management .....	32
10.3	Factory Settings, Unit Specific Parameters .....	32
10.4	Optional SW- Packages .....	32
10.5	Data Transfer .....	33
10.6	Data Exchange via PC .....	33
10.7	Transferring New Firmware to the Competino .....	34
11	Landing in Water.....	34
12	Guarantee and liability .....	34

## 5 Analog Vario

The resolution of analogue vario is 40 fpm or 0.2 m/s.

The first full-scale range is from +/- 0 to 800 fpm (+/-4 m/s) after which the display switches automatically to a second range from 800 to 2000 fpm (4 to 10 m/s).

The **time interval** (damping) over which the measured climb rates are averaged for the analogue (and associated sounds) is factory set at 1.2 seconds. This can be changed to any value between 0.6 sec and 4 sec. in Menu/Basic Settings/Vario-Speed-Average. If the time interval is too short, the vario is very twitchy; if too long, it's rather sluggish. A lower dampening value is preferable for smooth light conditions. A greater dampening value may be desirable in rough turbulent conditions. Note: This setting should not be confused with vario integration (averager) that can be set for the digital vario display.

A small pre filter can be adjusted to be used as a turbulence filter. It can be adjusted from 0.1s to 1 s. (Settings 1 to 10)

### 5.1 Altimeter and Air Pressure

The Brauniger Competino has 3 altitude displays.

**Alt1** is always the altitude above sea level (QNH).

**Alt2** is a reference height; it can be altered or zeroed at any time

Press F1 several times until „Mod A2“ appears. The arrow keys change A2.

F2 resets A2 to zero.

**Alt3** cumulates the gained height over one flight

Among the user selectable fields there is another altimeter called **“Flight-Level” FL (ft)** ; It cannot be adjusted by the user and is based on an air pressure of 1013 hPa at mean sea level.

Altimeter Alt1 should be adjusted to display the correct height above sea level. It is originally set by the manufacturer to a sea level pressure of 1013hPa. Since this is seldom the case, the correct altitude should be set before commencing each flight by using the arrow keys, ▲ increases altitude, ▼ decreases altitude. The Info line is telling Mod Alt1 ▲ ▼ . By means of this adjustment the air pressure display changes too. This air pressure (QNH) always refers to sea level.

During flight recording Alt1 adjusting is blocked.

The user can obtain the altitude of a location even if this is unknown by setting the sea level air pressure (QNH) (rec. from the radio) in the set up menu. Or he/she can press the F2 key. If the unit receives satellites the GPS altitude is taken over to Alt1. If there is no Satellite reception the 1013 hPa altitude will be used. (Same as FL (ft))

A2, A3, FL (ft) and QNH can be displayed within the user selectable fields

If Alt1 is set to zero for any planned landing area, then the height above this location will always be indicated after starting. The associated air pressure (QFE) is the actual air pressure in hPa at this spot, which deviates from QNH, the pressure at sea level, according to the difference in altitude.

### 5.2 Acoustics and Volume Level

In the acoustic menu, most of the parameters can be set to fulfill most of the pilots wishes.

Each time the key **⏪/Route** is pressed briefly, the volume level is increased by 25%. The adjustable sound levels are: 0- 25% - 50% - 75% - 100% - 0. The value of the chosen volume level is displayed on the status line.

**Automatic volume control:** The basic setting levels 25%, 50%, and 75% will be slowly increased automatically once the airspeed exceeds 40 km/h (25 mph). It is impossible for the volume to exceed 100%.

The following settings can be made in the menu under 'Basic Settings /Vario tone'.

**Audio thresh.**

**Threshold** To avoid the climb acoustic starting on the ground or during very slow climbs in flight, the starting point can be set from **0.2m/s to 0.4m/s**.

**Asc. F**

**Beep frequency** The basic frequency will be heard when the vario is at 0m/s, except when it is suppressed at the starting point.

**Mod.**

**Modulation** (see graphic below)

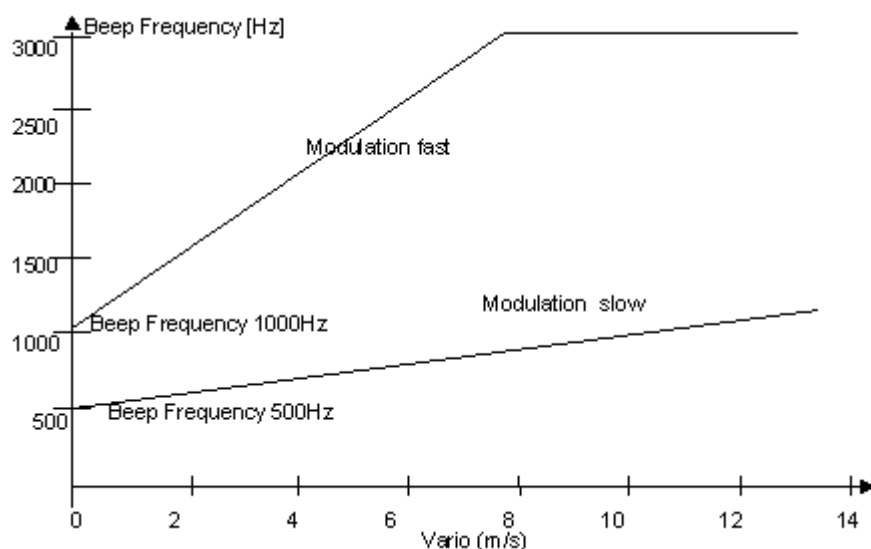

**Pit.**

**Pitch, broken tone interval** (see graphic below). The broken tone intervals increase in pitch with height

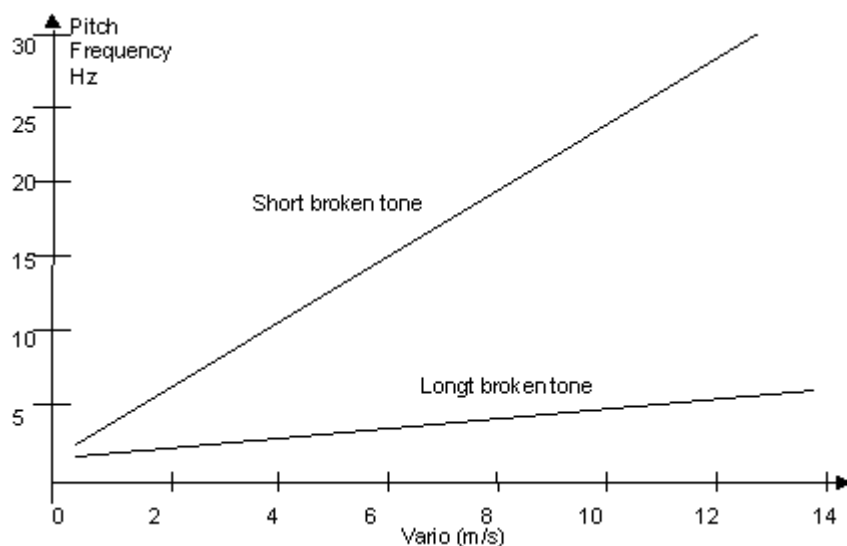

## damp

### Dampening

The vario value is re-calculated every 0.2s. Rapid vario changes may result in wide variations in tone frequency (pitch). The ear registers it as a fast piano effect. In order to change this, a damping may be added. Damping the rapid tone and frequency results in the vario being more settled.

## Sink tone thres.

### Threshold

The starting point can be chosen as in climb acoustic. This function can also be chosen during flight with the F1 key "Nxt Fnc". If this function is activated, the sink tone threshold can be adjusted with the  $\pi$ / $\theta$  keys. With F2 „SNK OFF“ or „SNK ON“ it is possible to switch on or off the sink tone. If the sink tone is activated, there is „SNK OFF“ visible and the sink tone can be switched off by pressing F2. If the sink tone is switched off, „SNK ON“ is visible and the sink tone can be switched on with the F2 key.

## SinkF

### Sink tone/alarm Frequency base

The basic tone deepens when sink increases. It cannot be set to a higher frequency than the climb acoustic frequency. The basic tone acoustic may be set lower.

The warning tone for stall alarm is a midrange tone with a fast interval and full volume.

All this settings can be controlled in simulation mode.

All of these settings can be tested in simulation mode.

If a low and quiet random noise can be heard at the beeper, even if it is set to 0%, this is a normal effect of operation.

## 5.3 Digital Vario

The digital vario has a resolution of 10 cm/s (20 ft/m) and a very wide measuring range of +/- 70 m/s.

The digital vario can be set to function as an averager (also called integrated vario), with an average time delay between 1 and 30 seconds. This is very useful in determining the actual strength of a rough thermal.

## 6 Speed

The Competino has an input for a vane wheel speed sensor. It shows the true air speed and begins to make correct measurements above 1km/h; it is also well-suited in determining the wind strength at take-off. In the **Basic Settings > Speed Correction vane** it is possible to calibrate the displayed speed from 70% to 150% (default is 100%).

The wind wheel sensor measures the true air speed. True air speed = TAS.  
Speed readings are only in digital displays.

Many paraglider pilots fly without a speed sensor. In this case we recommend displaying only the GPS-Speed (ground speed). From SW Version 1.12 up it is possible to display the Air Speed, even when flying without the vane sensor. The value is found by a vector addition of Gnd Spd and Wind. To get the wind in strength and direction, the pilot has to fly a full circle regularly.

## 6.1 Stall Alarm

This Alarm is audible, consisting of short beeps with 100% volume.

The speed for activating the stall alarm can be adjusted in the Basic Settings, and likewise, the altitude can be set to the point from where up the alarm is active. If the stall alarm is set at the lowest adjustable value of 0 km/h (mph), it is turned off.

## 7 GPS Functions

The use of GPS receivers has become indispensable for navigation today. A chain of satellites circles the Earth. It is possible to determine your position very precisely anywhere in the world by receiving several satellites at the same time.

### 7.1 Assessment of Reception Quality

The integrated GPS Receiver can follow up to 16 satellites at the same time. After turning on the unit it is necessary to receive at least 4 satellites to fix position for the first time. Once logged on, 3 satellites (for 2D positioning) are sufficient for further navigation. However, if you want to record altitude too (3D positioning), then four satellites are required. For competition flights it's always necessary to have 3D positioning. There is a table in the receiver, **The Satellite Almanac**, in which the path, place, and time of all satellites are kept with reference to the receiver. The Almanac is continuously updated during signal reception. However, if the signal to the Almanac memory is disrupted completely or the unit is taken 200 km or more from the last reception point, then the Almanac has to be re-established; it can take 10 minutes to determine the new position. Power is still supplied to the almanac's memory even when the unit is turned off.

The instrument loses the Almanac if both battery banks are removed.

When the receiver has been moved a great distance, you can help facilitate the connection with the Almanac by putting in the approximate new position (whole number coordinates suffice) in the Set Up mode under "Basic settings/GPS Init". With the antenna unobstructed the unit will normally recognize its position after a few minutes.

If the receiver is turned off for only a short period of time (less than 2 hours), it takes less than a minute to determine the location. Buildings, mountains or thick forest affect reception quality. Therefore, you should always look for the best possible visibility around you and the antenna under the Compeo label should point upwards. When the unit is fastened, it should not have more than 45° deviation from a horizontal position.

Because the receiving strength of the satellite signal is only 1/1000 of mobile radios, these radio receivers and other disruptive factors (like notebooks) should be kept as far away as possible from the Brauniger Competino.

Together with the navigation signal, information about the number of received satellites is shown on the right side of the bar scale. One angle is equal to one satellite with good reception. The longer the bar, the better is the reception.

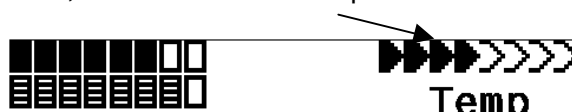

### 7.2 Compass and Flight Direction

In contrast to a normal magnetic compass which is oriented to magnetic north, the GPS compass can show direction only when the user moves about. However, it has the

advantage that it is not subject to any grid deviation and does not show any deviation as a result of iron or any magnetic material either. Its zero point always corresponds with true geographic north (**0 or 360 degrees**). The course that is the flight direction (= Track), is calculated from your movements.

If the user remains stationary at the same location, then the course and compass needles are inoperative. The exact course (that is the direction in which the user travels over ground) is always at the top of the compass, but can also be read in the display "Track". When circling in a thermal the compass rose appears to turn; in reality the needle does not move; the unit along with the aircraft, moves around the rose.

### 7.3 Track and Bearing

As is the convention with GPS receivers, the **Track** is defined as the route of the aircraft over ground. Geographic true North is always 0 or 360 degrees (East 90, South 180, West 270 degrees). The bearing is the direction to a specific destination or waypoint from the aircraft, expressed in the same way as above.

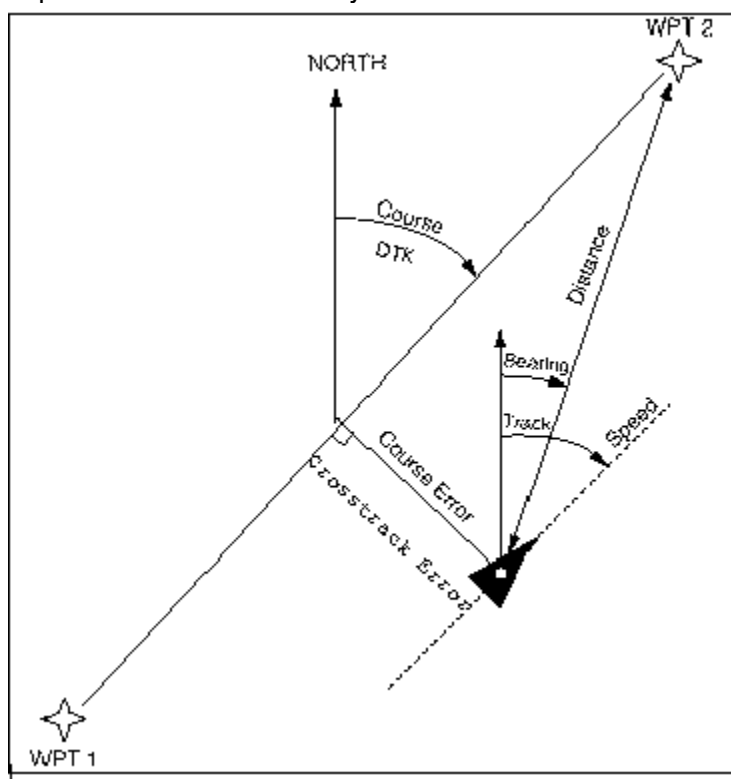

Note: A Tracklog is the result of recording many different position points during a flight.

### 7.4 Groundspeed

The GPS receiver fixes its position once every second. Speed over ground is derived from the distance between these positions. Only from the difference between airspeed and groundspeed can one make conclusions about the wind's influence, and ultimately these are the most important pieces of information a pilot needs during flight. The ground speed should appear at all times in an user selected field.

### 7.5 Glide Ratio (=L/D Ratio)

By definition, the glide ratio is calculated by taking the horizontal distance traveled and dividing it by the height lost.

Following different types of Glide ratio can be selected within the user-selectable fields.

- Glide ratio through the air:  
 $L/D \text{ air} = TAS / Sink$  True airspeed divided by sink
- Glide ratio over the ground:  
 $L/D \text{ gnd} = GS/Sink$  Ground speed divided by sink
- Required glide ratio in order to reach the chosen destination from the present position.  
 $L/D \text{ req.} = \text{Distance to the waypoint} / \text{height difference to the waypoint.}$

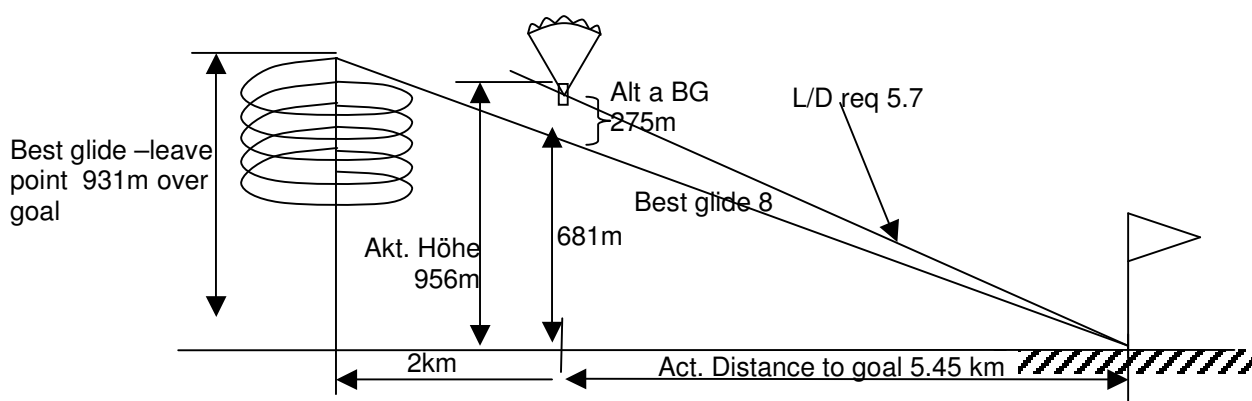

- Required glide ratio in order to reach the goal of an active route, from the present position.

$L/D \text{ r.Gl.} = \text{Distance to the goal over the next waypoints of a route} / \text{height difference to the waypoint.}$  This userfield is only active if a route is active. With this L/D the pilot can decide if he would fly directly to the goal or if he need to take altitude in a thermal. The calculation does not take into account if one ore more waypoints between the actual position and goal are higher than the direct beam from the actual position into goal. The distance to goal is calculated as described in chapter 7.10.

## 7.6 Head, Cross and Tail Winds; the Wind Component

During a goal flight or in calculating a final glide, it is the wind component (i.e. the difference between Ground speed and Air speed) that is important. In most cases the wind does not blow directly from the front or from behind, but from the side. If the wind component "Spd-Diff" (in the user defined fields) is positive, then the pilot will fly with a tail wind and the glide ratio over the ground will improve. If it is negative the glide ratio will worsen. The Brauniger Competino takes the wind into consideration when calculating the final glide. (In order to find the correct angle between the destination and the wind when a strong cross wind is present, please refer to the section Goto function.) The calculated wind speed can be displayed in a user selectable field.

Note: If the wind sack covers the wind directions N E S or W, the letter disappears.

## 7.7 Wind Direction and Strength

It is very important to know the wind direction and strength before an out landing.

The wind strength can be selected within the user defined fields. It is necessary to fly one or two complete circles as steadily as possible. Whilst circling, the Brauniger Competino determines the wind direction and strength. The calculated wind speed can be displayed in a user selectable field.

The instrument calculates the wind from the difference between Airspeed and Groundspeed. Wind direction is shown in the compass rose by a small windsock. During the landing approach this symbol must always be at the top.

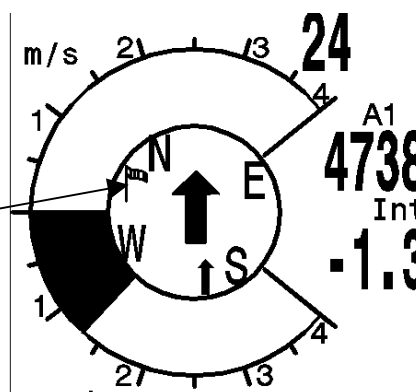

## 7.8 Waypoints and Co-ordinates

A waypoint is any single point on the earth's surface that you would like to go to. The Brauniger Competino can save up to 200 different waypoints. Each waypoint can have up to 16 characters, e.g. "**Laber Airfield**". In determining the waypoint, it is also necessary to enter the altitude, i.e. "**1865**" meters above sea level. We still need the waypoint co-ordinates. (Please also refer to C3 Waypoints — Alter, Delete or Add.)

For this the Brauniger Competino utilizes the most international and commonly used geographical maps with the name **WGS84** (World Geodetic System 1984). This reference system assumes that latitude is measured from the equator (0 degrees) to the North Pole, 90 degrees North, and to the South Pole, 90 degrees South. Longitude is measured from the Greenwich meridian (London 0 degrees). East is positive (up to 180 degrees). West is negative (-180 degrees).

UTM and Swiss Grid are also possible.

The Brauniger Competino also understands waypoints entered according to the standardized convention of using 3 letters and 3 numbers. (Created by Brauniger) Example: *LAB167* indicates a waypoint with the name *LABxxx* and an altitude of **1670** meters amsl.

In Basic settings/Coordinate format one chooses the following Input or Display formats

- 1) Degrees Minutes Decimal places of minutes dd°mm.mmm
- 2) Degrees Minutes Seconds dd°mm'ss"
- 3) Degrees Decimal places of degrees dd.ddddd
- 4) UTM ( a grid with a 1km raster in both E-W and N-S direction )
- 5) Swiss grid

Basically one should always try to use Nr 1) (=factory setting) because only this format is using exactly the same calculation format as the GPS receivers do and guaranty the highest accuracy. With the other formats rounding errors could sum up to 15 m in worst case.

The instrument calculates positions only in the WGS84 geodetic system. It is not possible to chose other geodetic date.

### 7.8.1 Waypoints - Alter, Delete, or Add

Waypoints can be managed at this location of the Main Setup Menu. **Waypoints can be managed very easy with Flychart 4.52 on the PC.**

After briefly pressing the *Enter* key the display shows the list of logged waypoints (WPs).

All WPs are arranged in alphabetical order.

If this list contains more than 6 visible WPs, a down arrow at the right lower edge of the list shows that additional pages follow.

To scroll down to the next page, press the **▶** arrow; WP 7 to 12 are now shown, and so on. You can select an individual WP with the **▼** or **▲** keys, and edit it by pressing the *Enter* key.

The first letter of the WP name will blink; again with the **▲** and **▼** arrow keys you can select the desired letter. There are numbers and letters, as well as a set of special symbols to choose from. By pressing the **▶** arrow you move forward to the next letter. With the F1 key you can switch between capital and small letters and numbers. You can enter up to a maximum of 16 characters.

Once the name has been entered correctly, confirm by pressing *Enter*. Now the waypoint altitude blinks, asking for any alterations. Again you confirm by pressing *Enter*. The WP position comes next. First the latitude is entered in degrees and minutes, and is confirmed by pressing *Enter*. Next are the decimals of the minutes. (Depending on the Co-ordinate-Format set in the Basic Settings) The same occurs with the longitude. Holding the key down longer changes the values to be set faster.

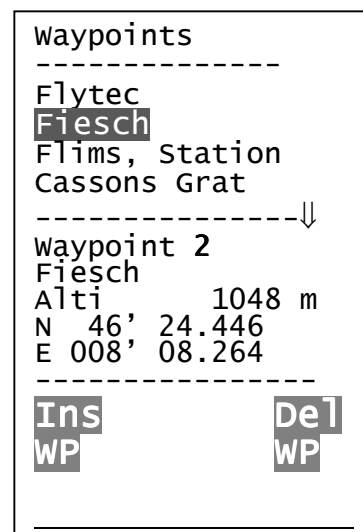

#### Deletion of Waypoints:

Selecting the waypoint to be deleted is done with the **▼** and **▲** arrow keys. Pressing the F2 key (Del WP) activates the delete function. To be on the safe side, the Brauniger Competino asks once again, "Delete Waypoint?" Yes or No are the choices available. It is possible, however, to stop the deletion process by pressing *Esc* and returning to a previous level.

#### Insertion of Waypoints

Pressing the F1 key (Ins WP) activates this function. Entering WP names, altitude, and position happens in the same way as described above. After confirming all entries with the *Enter* key, the new WP is inserted alphabetically in the list. Altogether 200 WPs can be stored by the Brauniger Competino.

**Note:** After entering the new waypoints (for example, for inputting them into a route) these can be used only after you have switched back to the normal flight mode by briefly pressing the **◀/Menu** key. In addition, the route into which the new waypoint should be inserted must not be active. Therefore, first change into route selection by prolonged pressing of the **◀▼/Route** key and with the help of the F2 key (Cancel Route) deactivate the route.

### 7.8.2 Current Coordinate Indicator

Provided the Brauniger Competino receives GPS signals, the actual position is displayed by pressing the *Enter* key in the unit's information field. After 20 seconds the previous display will automatically reappear. This function is useful in relaying your location after landing to a person coming to retrieve you. Every time the Marker function is called, the coordinates are also displayed

### 7.8.3 Distance to Waypoint

The horizontal distance is displayed for the viewer to the chosen waypoint as long as the destination has been input automatically or manually with the Goto function. For distances under 10km the resolution is 10m, if farther it is 0.1km. (Please read “ Goto-Function”)

The distance to a WP is always measured to the centre of a WP cylinder and not its circumference.

### 7.8.4 Distance to goal

This userfield shows the distance between the actual position and goal calculated over the next waypoints in a route.

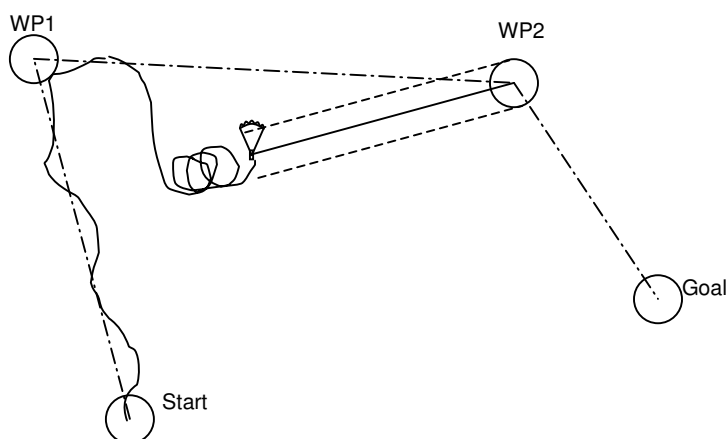

### 7.8.5 Distance to the waypoint cylinder radius

To ease the decision, when to turn and head for the next waypoint in a competition route, the distance to the cylinder radius can be showed as user selectable field. This is specially useful with start-cylinders, because the pilot does not always remember the actual radius of the start-cylinder.

### 7.8.6 Distance to Takeoff

The same applies for the distance to the start place. The instrument stores the coordinates of the point when it recognizes a valid flight. Flight recognition is performed if the speed is more than 10km/h for at least 5 seconds. This is normally valid near the start place

### 7.8.7 Saving the Current Position

(Not available in V1.10)

Every now and then a pilot may want to save the immediate position as a waypoint. To do

this press the key  for 3 seconds. As confirmation you will hear a double peep and those current co-ordinates will be stored in the memory as a waypoint and displayed in the two bottom lines. The Brauniger Competino uses the letter M (for marker) for the waypoint designation and then the date and time.

Example: **M.22.04 11:16:49** for 22 April 11 hrs.16 minutes 49 seconds. (UTC). Of course this WP name can be changed later into a more meaningful name, i.e. “Aunt Renate”.

## 7.9 Goto—Function

Prolonged pressure on the *Enter/Goto* key switches the lower half of the display into the 'Goto' mode. This function allows you to search for a waypoint stored in the memory of the Brauniger Competino and choose it for a flight to goal. At the same time the next five waypoints are listed in alphabetical order. The number after the WPs names indicates the distance in km, the 2. number shows the direction to WP (Bearing). After pressing the *F1 (Displ.Alti.)* key the precalculated arrival altitudes to the 5 WPs are shown in place of distance.

In practice there are 5 final approach (final glide) calculations to the WPs made at the same time.

**Note:** Only the WP the pilot is directly flying to (  $\pm 20$  degrees ), the wind component is taken into consideration for the calculation.

Key *F1 (Displ. dist)* switches back to the distances. If you search for a WP with the  $\blacktriangledown$  key, it will be selected when *Enter* is pressed. The Goto function can be deactivated with the key *F2 (Cancel Goto)*.

The big black arrow in the center of the compass is pointing directly towards goal.

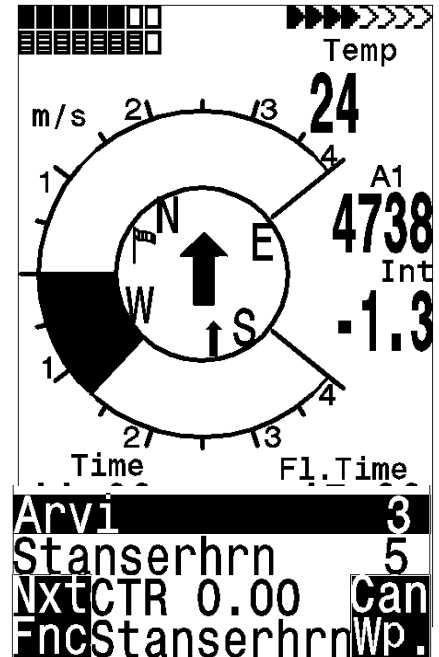

If a strong cross wind is encountered on the way to goal, the correct angle between the destination and the wind can be found as long as one carefully changes the direction of flight against the wind, until the directional pointer in the compass rose points directly upwards. The large arrow in the compass will now look like the one at the title photo. By doing this you can be sure that the flight path over ground is in a straight line to goal and thereby the shortest one. The well known "pursuit curve" is thus avoided.

Also amongst the user-selected displays is the safety height above the best glide path (Alt a. BG). While circling upwards before approaching the WP, this height will show 0 when the pilot should be able to reach the goal by flying at the best glide speed. Every meter above that means a greater safety margin.

The Alt a. BG then shows how much 'security height' the pilot will have available to use if necessary in order to compensate for unexpected sink. Under no circumstances should the pilot go ahead and fly towards goal if the Alt a. BG (Height) shows zero or negative numbers (reaching goal would then be impossible without finding lift on the way).

## 7.10 Flying Routes

A route is an arrangement of various waypoints. Of course, the waypoints used on a route have to be saved in the unit's memory.

In contrast to the **Goto** function where you have to choose the next waypoint from a long list by prolonged pressing of the **Goto** button, you can fly along a route by briefly pressing (next WP) or (previous WP). This function must be chosen with **F1**. (Next Function) Only routes with at least one waypoint can be chosen.

To choose a route, you press the button  $\blacktriangleleft$ / Route for a few seconds.

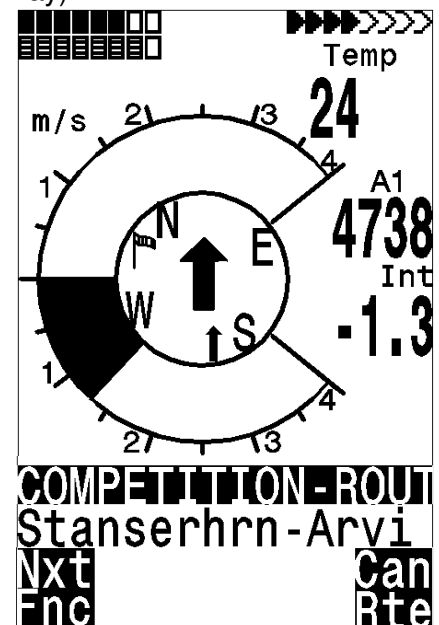

Each route should also be assigned a route name, such as "Karwendel Triangle".

It makes sense to store many well-known thermal sources as waypoints along a route. The pilot does not have to feel compelled to reach these waypoints and at times he/she may be high enough to jump a waypoint on a route, while at another time he/she may have already found a thermal several kilometers before reaching the waypoint.

Of course there is still the option of looking up other, possibly closer, waypoints without leaving the current route by using the Goto function. Altogether, the Brauniger Competino can have up to 20 routes set. The same waypoint can be used more than once along a route, and the same waypoint may occur on other routes as well. Once a waypoint has been used along a route, it cannot be deleted from the list.

From version 1.12 on, it is possible to display the user field Dist GI . This is the distance over the all remaining waypoints, calculated from the actual position. Additionally it is possible to show the Altitude above Goal **Alt a. GI** in a user field. This calculation takes the Windspeed and direction into account, which was derived from flying one full circle.

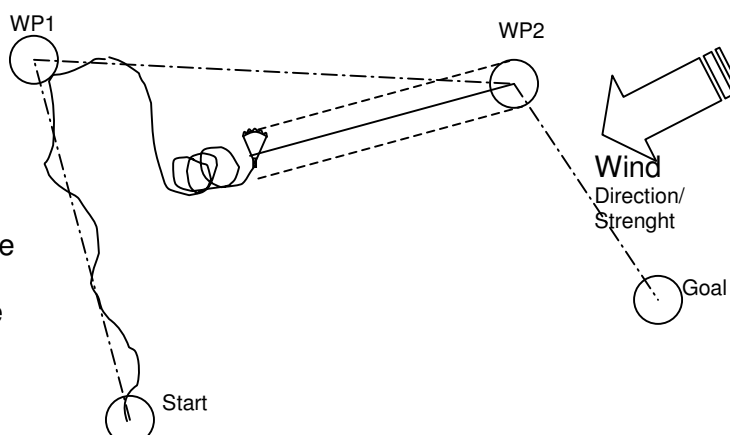

It will be assumed that the pilot flies on the track between the following waypoints. To the next waypoint, the instrument calculates the direct way to this waypoint. It will be also assumed, that the pilot flies with his best glide ratio. With this two assumptions, it is only the approximate height above goal because the instrument cannot know the precise wind conditions and how the pilot flies the way to goal. But it can be a help to fix the strategy.

### Direction arrow to the next waypoint:

In the middle of the compass rose a thick black arrow points to the next waypoint

The arrow to the over next waypoint is a shaded arrow behind the black arrow.

With the Function key F1 one can choose following input options:

- Next ▲pr▼WP = next or previous Waypoint
- H/T man. ▲▼ = Manual or automatic\* input of wind component (Head/Tailwind)
- Mod Alt1 ▲▼ Modify Alt1 ; (only possible so long no recording takes place )
- Mod Alt2 ▲▼ = Modify Alt2
- Sink Thresh ▲▼ Sink acoustic On/Off with F2 or alter with the arrow keys

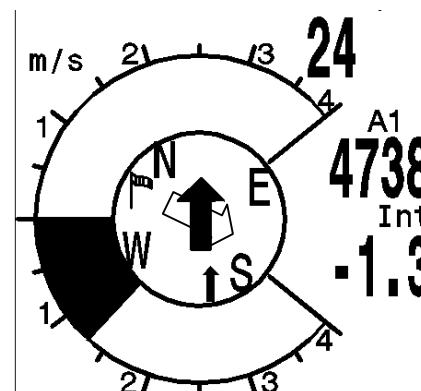

\*automatic means: the wind component is calculated by the difference of Gnd spd - Air spd (a negative result signifies a Headwind, while a positive result signifies a Tailwind)

## 7.11 Routes Set - Delete - Alter

You reach any stored routes by marking the menu point Routes in the Main Setup Menu.

With less effort Routes can be transferred with the program Flychart 4.52 or others from your PC to the Brauniger Competino. Routes saved in the Brauniger Competino appear after pressing the *Enter* key again. (Maximum of 20 routes) From these you can select one of the routes to be deleted by using the ▼ and ▲ keys; press *F2* (Del.-Route) to delete or *Enter* key to alter. However, by pressing the *F1* key (Ins. Route) a new route can be created.

A route is a string of waypoints. (Of course the WPs have to be already in the Brauniger Competino's memory). If a WP is used in a route, then it can no longer be deleted.

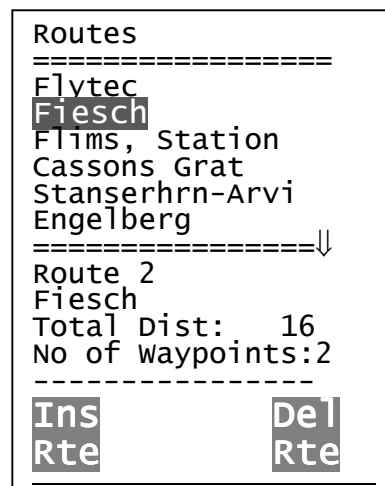

### 7.11.1 Setting a New Route

After pressing the *F1* key (Ins.Route), first a name has to be entered for the route. The cursor will blink on the first letter of the word "Xxxxx". By using the ▲ and ▼ keys you alter each to the desired letter. By using the ► key you proceed to the second letter, change it, and so forth. By pressing the *Enter* key you conclude the entry of the route name. At this time the individual WPs need to be added. The list of the available WPs appears in a alphabetical order in the bottom half of the screen after pressing the *F1* button (Ins.Wayp). At the same time you see the request: Select Waypoint No1. Again by using the ▼ or ▲ keys you search for the first WP and it is added to the route by pressing *Enter*. This is indicated in the upper half of the screen. Press the *F1* key (Ins.Wayp) again. Once more the waypoint list appears and you can select the second point. Press *Enter* to add this to the route, and so on. The highlighted waypoint (offset in black) in the route is always the last one entered, which means that the function "Ins.WP" will set the next WP to be entered after the one highlighted in black. If you want to insert an additional waypoint after WP1, then you highlight WP1, press the *F1* key (Ins.WP); the reference Select Waypoint No 2 appears.

If you determine, for example, that Waypoint No. 4 must be changed, then you select it and delete it( with *F2* ) and insert a new one by pressing *F1* . Note: The marked WP before pressing *F1* must be WP3. Again the list of available waypoints appears and the prompt Select Waypoint No 4. After selecting and pressing *Enter*, the old waypoint is replaced by the newly chosen one.

If you want to delete a waypoint from the route, then you select it and press the *F2* key (Del. Wayp) The WP is deleted from the list without any additional prompt.

### 7.11.2 Altering a Route:

You select a route to be changed with the ▼ or ▲ keys and confirm with *Enter*. The route name is changed first. If this is not what you want, then it is sufficient to press *Enter* again in order to get to the waypoints. As described in the last paragraph, the additional WP can be added or deleted now.

### 7.11.3 Deleting a Route:

You select the route to be deleted with the ▼ or ▲ keys and press *F2* (Del.Route). To be on the safe side the Brauniger Competino inquires once again: Delete Route? that can be answered with Yes or No. However, it is not possible to delete the FAI-route.

### 7.11.4 Changing a route into Competition Route:

Call up Route (Main Setup Menu > Routes). With the ▼ or ▲ keys go to the desired route and press Enter.





Now press  The display asks “copy to Competition route?” confirm with “Yes”. Please note: start cylinder, cylinder radii, and start time have to be set separately. All radii are reset to the default values of 400m.

## 7.12 The Competition Route

In contrast to the routes described above, the Comp. Route has waypoints which are mandatory and have to be reached; for example turning points in competition or on Comp. performance flights. The regulation, which only recently came into effect in documenting distances flown, replaces the detailed and often difficult to interpret photographic documentation with photo sectors; it is now totally dependent on the recording of GPS receiver position data (Tracklog points).

When flying Comp.-routes the pilot will be warned by an acoustic alarm when crossing the circumference of a turn point cylinder or when entering / leaving the start cylinder and the unit switches automatically to the next WP. The competition route can be called up by

prolonged pressing of the  key and confirmed by pressing *Enter*. The competition route remains active even after switch off of the instrument. It can only be deactivated by

prolonged pressing of the  key and then pressing *F2 Cancel route*. Here any of the WPs can be defined to be the Start WP.

### 7.12.1 Competition - Route Set - Alter - Delete

When a Competition Route (which is treated differently than a usual route) is called up during flight, there are only a few differences when setting or changing it. The route can be set up with the help of the keypad similar to a normal route or can be transferred from the PC. The Competition Route can be altered, WPs in it can be erased, but its name, however, cannot be deleted.

Each one of the other routes can be copied to replace a Competition Route by pressing the



key . The same key is used to assign the status “Start Cylinder” to one of the waypoints. For the Start Cylinder, the user chooses if the race begins by “Entering or Exiting” the cylinder circumference. For each of the WPs in the Competition Route, a different cylinder-radius can be assigned (20m ... 200km). There is also a count down timer linked with the Start Cylinder. This lets the pilot know exactly how many minutes and seconds are left until the window is open. It is possible to use the same waypoint several times (e.g. the goal and the landing place) with different radii. If the competition route is empty it can not be activated

### 7.13 Flying a competition route

Because Brauniger Competino’s GPS receiver confirms its new position every second, it only takes one second for the pilot to know that he/she is crossing the cylinder circumference. In this case a long, unmistakable tone lasting 2 seconds (**CMP-Sound**) and the unit automatically switches to the next route waypoint. It is guaranteed that several track log

points within the cylinder are stored at one second intervals in the memory of the Brauniger Competino, totally independent of what recording interval is used during a standard flight.

Usually the Start cylinder is the first position of the competition route. (not mandatory) If during setting or

changing the route, the  key is pressed prolonged, an "S" for Start-Cylinder appears behind the waypoint's name and the cylinder radius. (The "S" disappears if the same key is pressed again) Only if a WP is marked with "S" it is necessary to set also a Start time and a Startmode : Enter or Exit. By confirming Enter or Exit he/she defines if the race begins by flying in or out of the circumference. If no Start-Cylinder is determined the pilots can launch whenever they want; the automatic switch over to the next WP occurs as soon the pilot is inside the cylinder.

COMPETITION-ROUTE	
=====	
Flytec	0.4S
Fiesch	0.4
Flims, Station	0.4
Cassons Grat	0.4
Stanserhrn-Arv	0.4
Engelberg	0.4
=====↓	
wp1/6 in Route	
Flytec	
Total Dist: 16	
Radius [m]: 2	
Start 14:15+05min	
Gates 02	EXIT

If in a competition a start cylinder and start time is defined, the start is valid if the start time is reached and the following conditions are valid:

- Startmode EXIT: If the pilot crosses the radius from inside to outside
- Startmode ENTER: If the pilot crosses the radius from outside to inside.

In Version 1.16, multiple start gates can be chosen:

It is now possible to set multiple start times in the *Competition Route*. Multiple start gates are only possible if they are evenly spaced. The number of gates and the interval must be specified (along with the first start and the start cylinder size) when the start point is defined in *Competition Route*. In the example below there are 3 starts gates with the first start at 12:30 followed by 12:45 and 13:00 start gates.

EXIT cylinder:

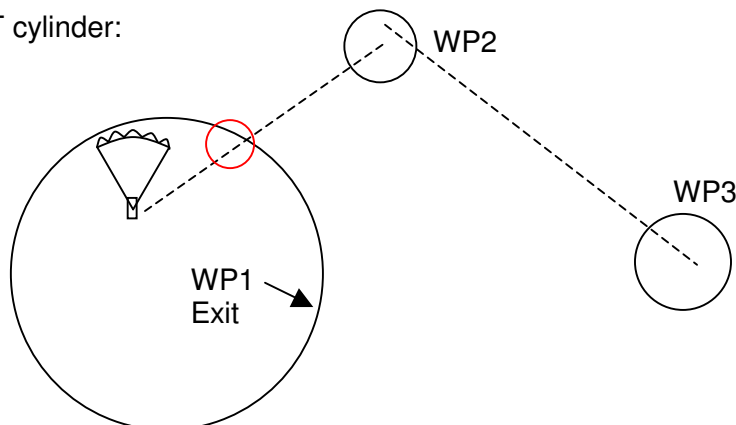

When the *Competition Route* is set as an exit start the "waypoint reached" signal will be given as soon as the start time is positive (countdown timer) and your position is in the start cylinder. It will also sound if the start time is positive and the pilot crosses the start cylinder from outside to inside. In both cases the sound is given to alert you that it is time to go to the next turnpoint and the next turnpoint will become active (in this case WP2). All calculations and the direction arrows are now with respect to WP2.

If the pilot wishes to take the next start gate, he must press the Prev WP key. If this soft key is not visible, it can be brought up by pressing F1 until the bottom line shows Prev/Next WP. By pressing the Prev WP key the instrument will set the start (WP1) as the active waypoint and increments the start time by the interval set in the *Competition Route*. If the last start

gate time has passed and the pilot presses Prev WP, the instrument will not increment the start time.

Note: It is required that the first turnpoint after the start cylinder is outside the start cylinder.

ENTER cylinder:

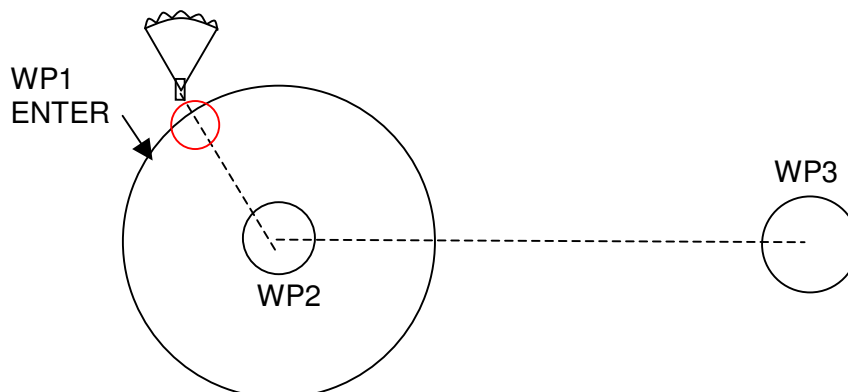

When the *Competition Route* is set as a *enter* start the “waypoint reached” signal will be given, as soon as the start time is positive (countdown timer) and the pilot crosses the start cylinder from outside to inside. The first turn point will become active and all calculations and the direction arrows will be made with respect to the first turnpoint (WP2 in the example).

If the pilot wishes to take the next start gate, he must press the Prev WP key. If this soft key is not visible it can be brought up by pressing F1 until the bottom line shows Prev/Next WP. By pressing the Prev WP key the instrument will set the start (WP1) as the active waypoint and increments the start time by the interval set in the *Competition Route*. If the last start gate time has passed and the pilot presses Prev WP, the instrument will not increment the start time.

Note: It is required that the first turnpoint after the start cylinder is inside the start cylinder (normally at the same position).

During a flight with defined starttime the pilot can see at the Info display how many seconds/minutes are left before the opening of the Start line. The time counter shows decreasing negative **numbers** **Only when the time counter has reached 0 and starts to count forward** ( now with positive numbers) the pilot can make up his mind to cross the circumference of the start cylinder from outside to inside if the start mode was set to ENTER and the other way round if the mode was EXIT. An unmistakable beeping sound occurs and the Brauniger Competino switches automatically to the next WP. The Dist.to WP always counts the distance from the present pilots position to the centre of the WP cylinder.

When the pilot has left the Start cylinder and the instrument has switched over to the next WP, pressing the ▲ ▼ keys allows you to toggle back and forth between previous and next WP. This is useful when a pilot wants to break off a task and restart at a later time.

Even during the flight along the Competition route it is possible to select additional waypoints (thermal sources) by pressing the *Goto* key (prolonged pressing), sorted according to their distance from the pilot. The WPs which are part of the Comp. route are marked with an asterisk in the displayed list; this means they must be over flown. The alarm remains active when entering a called up waypoint cylinder along the route, even if a waypoint not belonging to the route has been selected. With the F2 button it is possible to toggle back and forth between the WP of the Competition route and another WP.

After completing a flight task, the WP belonging to the Comp. route will be listed in the data transferred to a PC under the header of the IGC file. A corresponding PC program can also check if the assigned task was completed correctly.

When setting up a Competition route without a start cylinder and without a Start time, the automatic switch over to the next WP takes part, as soon as the pilot is inside the 1. cylinder. So it makes no sense to choose the "Take off" place for the 1.WP because immediately after receiving satellites the unit switches over to the second WP.

With the Function key F1 one can choose following input options:

- Next ▲pr▼WP = next or previous Waypoint
- H/T man. ▲▼ = Manual or automatic\* input of wind component (Head/Tailwind)
- Mod Alt1 ▲▼ = Modify Alt1 ; (only possible so long no recording takes place )
- Mod Alt2 ▲▼ = Modify Alt2
- Sink Thresh ▲▼ = Sink acoustic On/Off with F2 or alter with the arrow keys

## 7.14 Final glide screen and final glide calculations

In the user selectable fields there is a field alt o BG (altitude above Best Glide). This is the calculated altitude over the path of best glide. A condition is however that on the way to the active WP no lift or sink air is present, that the wind considered for the calculation does not change and that the correct the best lift/drag ratio is entered in the basic settings. If alt a. BG is positive, then the pilot has a safety altitude to reach the active WP. If this height is negative, then the pilot must thermal up the indicated height to reach the goal. See also chapter 7.10 where a final approach computation over several WP is described. After repeatedly pressing the key Esc additional screen appears, which plots the final approach calculation. A cross hairs shows the path into the goal; a symbol of a glider the relationship of this the position of the pilot.

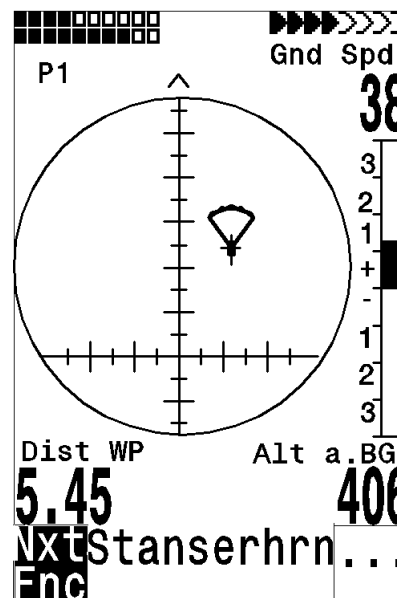

The horizontal scale of the cross hairs shows the difference (As example caused by shearing winds) between track and bearing to goal. In the example the difference between the actual track and the bearing is 22° to the right.

The vertical scale shows glide ratios. The cross hairs shows the best glide of the glider which was set in Basic Settings. The symbol shows the glide ratio (Distance/ Altitude) needed to goal, corrected by the actual wind. Every tick shows 0,5 L/D.

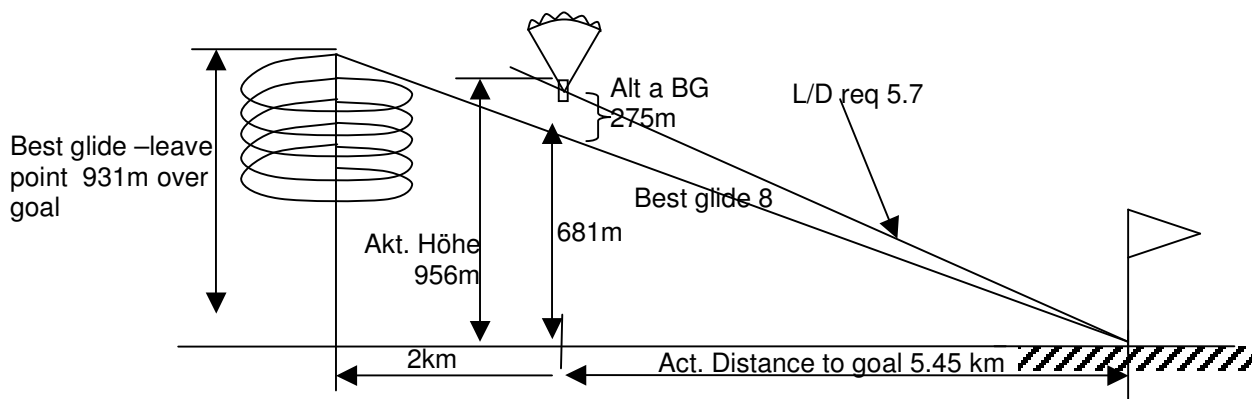

In the example above the glider has a best glide of 7 which was set in the basic settings. If the pilot flies on the path of best glide, the symbol is in the cross hairs and Alt. A. BG is zero. Because his distance to goal is 5,45km his altitude should be  $\%450/7= 780$  above goal. Alt a. BG shows 406 m. He is now  $780+406=1186\text{m}$  higher than goal. The I/D required is  $5450/1186 = 4,6$ . The symbol points on this  $7-4,6 = 2,4$  ticks above cross hairs.

The strategy is, to hold the symbol in the cross hairs. Experienced pilots will hold the symbol above the cross hairs to have enough margin.

During thermalling, the symbol stays on the vertical axis. If the difference between the actual L/D and the best glide is more than 20, the symbol is grey and stays in the cross hairs. If L/D difference is less than 20, the symbol disappears and comes back if the difference is less than 6. If the symbol goes to the upper margin it will appear grey.

During thermalling there is a small arrow ^ in the upper part, if the difference between track and bearing is less than +/- 10°. During gliding the arrows <^> recommend in which direction to head. If the symbol reaches the right or left margin it is grayed out. In this case we recommend to go back to the vario screen to see the full compass rose including the direction arrows.

## 7.15 Relocating Thermals

With weak or widely dispersed thermals this function helps to relocate any lost thermals. A small arrow pointing up in the double ring of the compass rose shows the direction to the last thermal with at least a 1 m/s climb. If this arrow is displayed at the top in the ring then you are flying towards the thermal. However, if the arrow is below in the compass rose, you are going away from the thermal. If you want to take advantage of this function, then the indicator "Dist. to ^" should be activated in one of the user defined fields. This value indicates the distance from the last thermal to the pilot.

In the Basic Settings one can adjust this value between 0,5 .. 3 m/sec . (Last therm. Threshold)

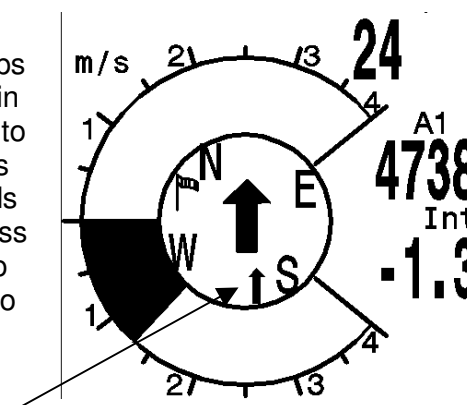

## 7.16 Restricted Area

It is possible to enter up to 150 restricted airspaces/restricted areas (CTRs) in the Competino. CTRs will be shown on the real-time map and can be polygons, circles or polygons with arc sections. The number of possible CTR's depends on the memory available in the instrument and the unlocked SW-Packages. The maximum number of

waypoints for each restricted area is 110 waypoints or elements. It is not necessary to duplicate the last waypoint. The Competino closes the area automatically.

- Without unlocking software packages it is possible to enter up to 20 CTR's (depending on the number points required to define the CTR)
- With a package release of SW package 02 it is possible to enter up to 150 CTRs (again depending on the complexity of the CTRs). To use this option software package 02 must be purchased from Brauniger.

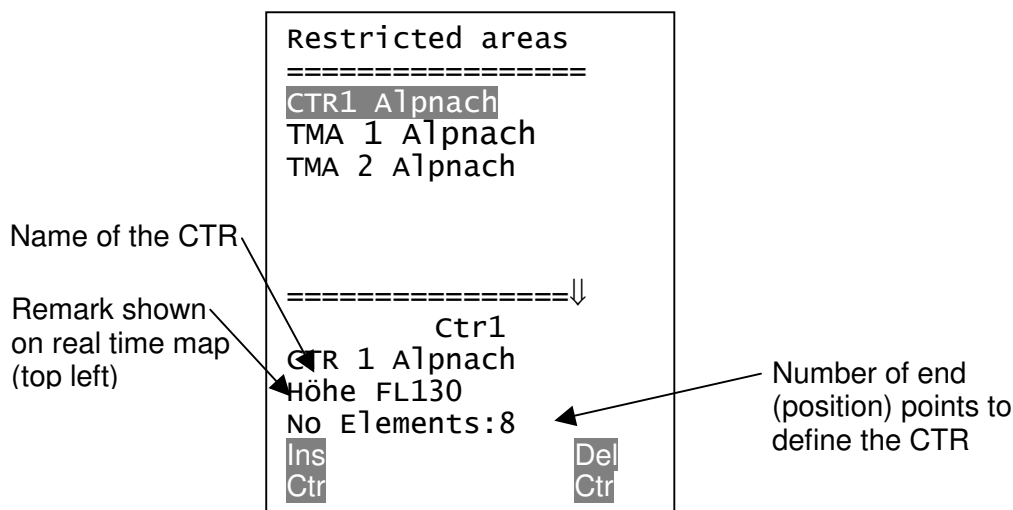

A CTR is defined by the end points of lines and arc segments or by the center and radius of a circle. The end points must be entered exactly in sequential order (clockwise or counter clockwise). The instrument will automatically connect the last point entered to the first point so it is unnecessary to repeat the first point at the end of the string. For mathematical reasons the distance between two end points in a CTR should not lie too far apart. The accuracy of the distance calculation will be increased if an intermediate point is inserted between two distant end points.

CTR's can be entered into the instrument manually in the Setup menu>Restricted areas, or more easily with Flychart. The procedure for manually entering CTRs is below and the procedure for using Flychart is in the FC help files.

If you define the points of a CTR the GPS coordinates (lat and Lon) of the point must be entered as well as the *Type* of point from the list below:

- |               |  |
|---------------|--|
| Point:        | End point of a line or arc   |
| Center:       | Center of an arc   |
| Startboarder: | Start point of an arc with direction (+ clockwise/ - counterclockwise) |
| Stopboarder:  | End point of an arc (+ clockwise/ - counterclockwise)                  |
| Circle:       | Center of the circle with radius in m                                  |

**Example:**

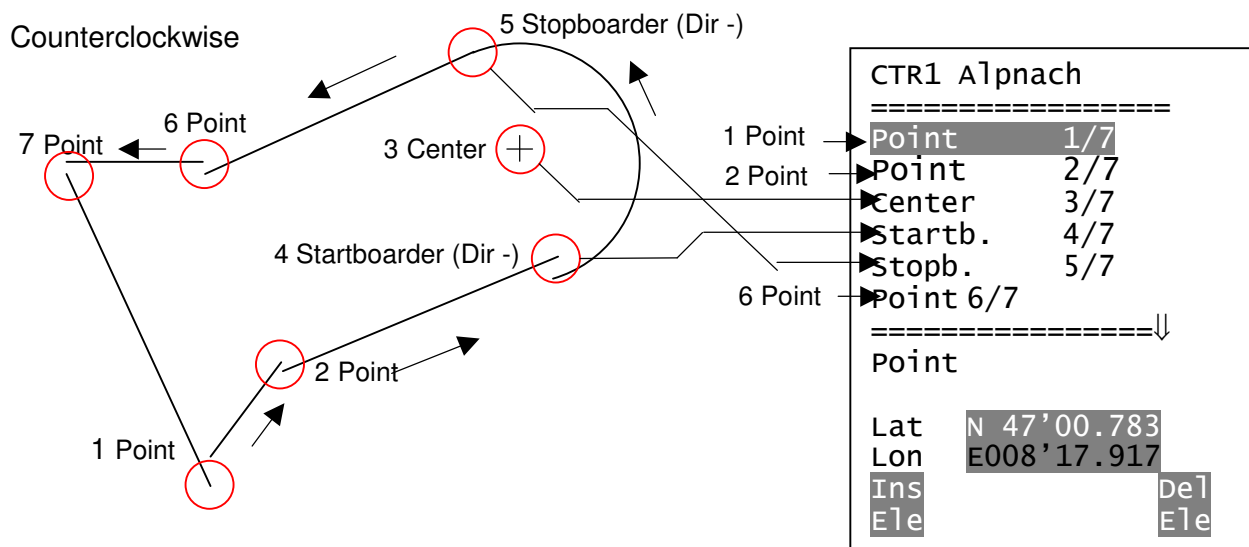

To Enter segments you must obey the following procedure:  
 Long, Lat center;  
 Long, Lat Startpoint of the segment;  
 Long, Lat End point of the segment;  
 Turning sense (+Clockwise, - Counterclockwise)

To enter circles it is sufficient to enter the center and the radius  
 Long, Lat of the center;  
 Radius in km

## 8 Flight Memory and Flight Analysis

In contrast to previous flight instruments the recording mode does not need to be specially activated as each flight is automatically saved.

The flight logging system used in the Brauniger Competino registers not only the flight altitude and the flight speed TAS (= true air speed), but also logs, with the GPS receiver switched on, the time, position of the pilot in the WGS84 co-ordinate system and the GPS altitude.

The value set in the Basic Settings/ record interval determines the time interval in seconds after a new data record is written in the Brauniger Competino's memory. A scan rate of 1 second is advisable for tests or aerobatic flights. The factory setting is 10 seconds.

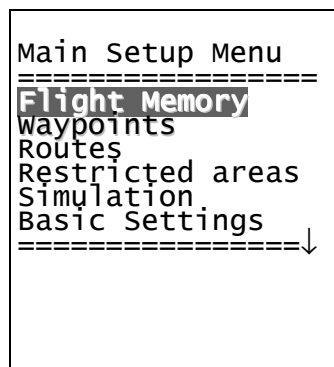

It is recommended to use a record interval between 5 and 10 s. Circles are still visible without producing too much data.. The factory setting is 10s.

For the beginning of a flight the following rule applies:

The start is recognized as soon as the ground or the airspeed reaches at least 10 km/h for more than 60 seconds or if the altitude difference is more than 30m within 60 seconds. In each case however, the previous flight history with up to 30 recording points is logged in the Brauniger Competino's memory.

Even the last 3 minutes before the start of the logged flight can be recognized as they are recorded with a 10 second recording interval. An end of flight is recognized if there is no movement for 60 seconds, and no change in altitude occurs. Then the flight analysis is displayed. The digital signature is calculated from this moment on and a notice in the user defined field draws attention to it. Please wait until the calculation is completed. You can return to standard mode by pressing the *Menu* key briefly.

FLIGHT-ANALYSIS	
Date:	24.09.04
Start:	06:19:06
Stop:	06:27:56
Fltime:	0:09:04
Scanrate:	10s
Max A1:	1153m
Max A2:	4273m
Max A3:	418m
Max Vario:	8.9m/s
Min Vario:	-6.6m/s
Max Speed:	73 kh
<b>Shw</b> <b>Map</b>	<b>Rec</b> <b>Sig</b>

If however, manual recording was chosen, recording starts 1 minute after the instrument is switched on and continues until the Esc key is pressed for 3 seconds. The unit asks you: "Do really switch off" and you confirm with "Enter". Now starts the generation of the digital signature which can last 1 or 2 minutes. Wait until this is done and press any key to turn off.

Take into account that modifying of Alt1 cannot be done after the start of a record. The user field Flight time starts to count up with the beginning of a record.

Flight Memory is situated in the first position of the Main Setup Menu. If you press the *Enter* key, the list of flights, stored according to date, appears. The most recent flights are in the first positions. The length of the flight is also shown. With the ▼ or ▲ key you can move through the list and choose the desired flight with the *Enter* key. The flight, with its benchmark figures, is indicated in the flight analysis. Individual flights can be deleted from the list by pressing *F2 Del.* Flight.

**Note:** Before starting a flight make sure that the GPS receiver shows at least 4 receiving satellites to get a valid recording.

## 9 User selectable fields

In the vario display there are a total of 3 user selectable fields which can be used as the pilot desires. In total, there are about 20 measurement options available. In order to assign a field, press the ◀ arrow key. The description of the corresponding display is highlighted by a black bar. Repeatedly pressing the ◀ key switches to the next fields. The ▲ and ▼ arrow keys enable you to select the following measurement to be displayed:

If nothing is changed after selecting a field, the instrument goes back to the normal function after 10 seconds and the previously shown display remains the same.

By pressing ▶ there are a second and a third page with other user fields available.

### 9.1 Temperature

The unit needs a temperature sensor, not only for compensation of the pressure sensors but also for automatically regulating the contrast of the display. The temperature reading can be in either Celsius or Fahrenheit. (Set-Up Menu/Basic Settings/Units)

**Note:** The sensor measures the circuit board temperature. The inside temperature of the casing can be slightly higher than the ambient air temperature, especially when in direct sunlight.

### 9.2 Time and Date

**Note:** Time, date and year does not need to be adjusted as it is automatically set by the GPS receiver. However, to set the unit to local time, any time zone difference from UTC (World

time) will need to be entered, which corresponds to a positive value if the time zone is east of Greenwich or a negative if west.

The date and time will be reset after a power fail of longer than 30s. Please check after you have changed the batteries.

### 9.3 Flight time

The take off time is automatically recorded. The clock for the flight time starts as soon as the speed over the ground or through the air reaches a reasonable flight speed. The flight time can be displayed in the user selectable fields. The unit will also recognize the end of the flight. In basic settings you can choose between manual and automatic start and ending of flight recordings

## 10 Other functions

### 10.1 Simulation

After choosing the Simulation mode in the Setup menu and pressing the *Enter* button, you reach this very interesting function. With the arrow keys and *Enter* you turn the Simulation to Yes and confirms again with „*Enter*“. Now the simulation starts at the last known GPS position. With the **▶** and **◀** arrow keys you can adjust the air and ground speed; the **▲** and **▼** arrow keys change the sink or the climb. If the stall alarm sounds, please increase the airspeed by a few Km/h

The softkey F1 is used to change different functions:

Next Func.	var ▲▼ spd ▶◀XX	to change Climb / Sink air- + Groundspeed
Next Func.	wind ▲▼ Trk ▶◀	Change of wind and flight direction
Next Func.	Mod A1 ▲▼	Modify Alt1
Next Func.	Mod A2 ▲▼	Modify Alt2
Next Func.	S.Thr -▲▼	Modify threshold of sink acoustic
Next Func.	Change page ▶	

Likewise, the **Goto** function can be called up to select a waypoint. If the direction arrow in the middle of the compass points upwards, the pilot is moving towards his goal and the distance to WP becomes smaller while at the same time the altitude naturally decreases. If you now initiate a climb with the **▲** key, the Brauniger Competino simulates circling up in a thermal; the compass rose turns and the distance to goal continuously changes between somewhat closer and somewhat farther away.

Under simulation you also can test the different acoustic adjustments as frequency, pitch and modulation during a virtual climbing. ( Basic Settings/Vario tone )

Please change back again to a sink flight.

If on your display there is a user field named Dist to ^ you see now, like during a true flight,

how your distance to the last thermal increases, while in the compass rose the symbol **↑** appears and shows you the direction where the last thermal has been.

You can also retrace a route flown. If you select the route as the Comp.-route, you will hear the characteristic tone upon approaching within 400 meters of the waypoint, which tells you, that you are inside the cylinder. You see the automatic switchover to the next WP too. If a start time was set, take care that the count down timer shows positive values. By pressing the ESC key you can switch to map display and observe the approach to the waypoint cylinder. The second transparent pointer in the center of the compass rose helps to minimize the flight path; no need to cross the circumference of the cylinder right angled.

Unfortunately, wind direction cannot be set; only a difference between Ground- and airspeed simulates head or tailwind influence. Press *F1* until the function: wind ▲▼ trk ▶◀ appears.

It is very informative to see how different head- or tailwinds influence the arrival altitude Alt a. BG above your goal.

The GPS receiver is turned off during the simulation, and in place of its bar the word "Simulation" appears.

A simulated flight is stored into the memory of the Brauniger Competino, but the Digital Signature is not valid.

## 10.2 Battery management

Two bar graph scales indicate the capacity of the batteries. The Brauniger Competino has 2 banks with 2 batteries each. Bank 1 must always be equipped. Bank 2 can remain free. However, we recommend to equip bank 2 also. As soon as the first bank is used up, the instrument switches automatically to the second bank. If the second bank is not yet used up, and bank 1 is equipped with new batteries, the instrument switches to the first bank again. After a long flight we recommend to insert the partly used batteries of the bank 2 into bank 1 and to equip bank 2 with new batteries. Thus it is ensured that the instrument can use up the batteries always completely, without the danger of having empty batteries during a flight. Before S/N 5500 the two banks in the battery compartment were changed.

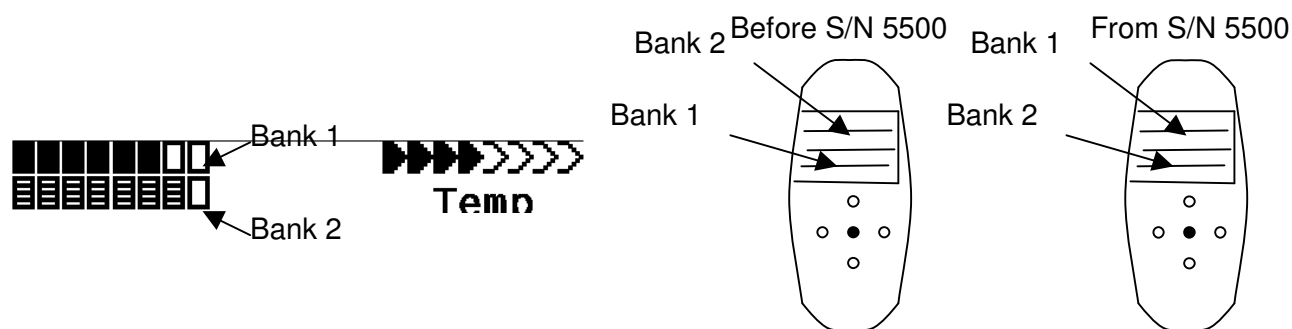

The following battery types could be used

2 pieces per bank Alkaline High Power Batteries 1.5 Size AA. Estimated life time  $2 * 13h = 26h$  together (recommended types: VARTA or Duracell)

2 pieces per bank NiMH Accu 2100mAh, 1.2V Size AA. Estimated life time  $2 * 11h = 22h$  together. The Bargraph shows only the actual battery voltage, not the capacity.

We don't recommend NiCd Accu because they have clearly smaller capacities and are not pollution free. The battery thresholds are optimized for NiMH Accus.

Please dispose of the batteries properly.

The estimated life time bases on normal temperature conditions. If the batteries are hotter or colder they have another capacity, and therefore another life time. The Bargraph shows only the actual battery voltage, not the capacity.

The inserted battery type is not recognized automatically. Because the battery types have different voltages and a different temperature behaviour, the battery type must be entered into the basic Settings. If the wrong battery type is specified, it is possible that the instrument switches off during switching between bank 1 and bank 2.

## 10.3 Factory Settings, Unit Specific Parameters

Beyond this set up level, which is not accessible to the pilot, all basic factory settings are stored. In particular, both the sensor specific parameters the serial number and all the calibration data are located here. This data is not lost even when the power supply is cut off.

## 10.4 Optional SW- Packages

With the help of a password code (obtainable from the manufacturer), additional special functions can be activated. For example up to 150 CTR's.

## 10.5 Data Transfer

All data entered by the pilot, including waypoints, routes, pilots names, etc. as well as the automatically recorded track log points of the flights undertaken by him/her are in the memory of the Brauniger Competino. Each track log point contains the time, position, GPS altitude, barometric altitude as well as the flight speed. In this way, it is possible to graph the Barogram, variogram, speed gram and course of the flight on a map for later evaluation. Recently, evaluation programs have been made available which are able to depict the flight in its appropriate landscape on a computer screen in 3D. In Flychart 4.52 it is possible to show the flight in 3D on a realistic landscape on Google Earth

## 10.6 Data Exchange via PC

The Competino's basic equipment includes a data cable for a serial PC interface (9 pol Sub D plug). Data transfer can occur in both directions. The connection occurs with: 57.600 baud; 1 startbit; 8 databit; 1 stopbit; no parity, Xon/Xoff

The following can be read via this RS232 interface:

- Serial numbers and pilot names
- Waypoint list
- Route list
- A selected flight (track)
- Restricted areas

The following can be uploaded to the Competino:  
Waypoints and routes and restricted areas

**Important:** the unit must first be switched on before plugging in the connection cable to the unit and the computer.

Before you transfer the waypoints and route data switch the Competino to the Setup Menu. You should make sure that the waypoints show up in the unit's waypoint list before you transfer a route from your computer.

If you wish to download flight data, switch the unit to the Flight memory mode, and display the desired flight on the Flight Analysis screen before transferring it to your computer. There are a number of PC programs on the market that allow communication with the Competino. We recommend the program Flychart which you can download from the Brauniger Website [www.Brauniger.com](http://www.Brauniger.com)

Other programs that permit data transfer with the Competino:

Trackview (Freeware)	Daniel Zuppinger (for OLC und CCC) <a href="http://www.softtoys.com/">www.softtoys.com/</a>
Compe-GPS	<a href="http://www.compegps.com">www.compegps.com</a>
Seeyou	Program well liked by sailplane pilots <a href="http://www.seeyou.ws">www.seeyou.ws</a>
GPSDump	Stein Sorensen . A simple program for IGC File dump. <a href="http://www.multinett.no/~stein.sorensen/">http://www.multinett.no/~stein.sorensen/</a>
Maxpunkte	Free program from DHV for reading flight data for evaluation and submission to OLC. <a href="http://www.dm-sh.de">www.dm-sh.de</a>

## 10.7 Transferring New Firmware to the Competino

As is the case with many other new developments, particularly during the introduction phase, improvements or feature enhancements may be expected. Periodically Brauniger will post firmware updates at [www.brauniger.com](http://www.brauniger.com), which can be downloaded by the user free of charge, and then uploaded to the Competino.

To be able to write to the Competino's flash memory with a PC, it is necessary to use a compressed file named "Flasher.exe" that is available in zipped form `flasher.zip`. In addition, the actual firmware to be uploaded must be obtained. It is called "Competinov113.moc" which corresponds to the version 1.13. Both of these are available from the download page at [www.Brauniger.com](http://www.Brauniger.com)

We recommend that you store all the related files in a separate subdirectory. (e.g. `c:\programs\BraunigerFlasher\`). After decompressing the ZIP file a number of files are created. Double clicking on the file "flasher.exe" starts the program. Under "Setup", the serial port (COM1 or COM2) can be chosen. You select the file to be transferred with the extension ".moc" by pressing on the "Start" key. The data transfer starts automatically. The numbers shown on the right side are the answers of the instrument.

Sometimes the Flasher will give an error. In this case, the cable must be unplugged, and the Competino turned off before making another attempt to flash the memory.

**Important:** Contrary to the instructions for data transfer of waypoints or routes, be sure that the 5020 is turned off when plugging the cable into the computer and the 5020.

**Important:** Never leave the PC cable hooked up to the unit when it is turned off. If this is done energy is consumed, and the battery can be drained.

## 11 Landing in Water

If you are forced to land in water it may enter the instrument. There is still a chance, however, to save it (or at least some of its parts). Once water has entered the GPS module it is definitely destroyed.

- The proper procedure is as follows: Take out all batteries.
- Open the instrument case at once.

If the landing is in salt water, rinse the circuit board and all areas affected with clean, fresh water. Dry the instrument carefully with warm air (hair dryer).

It is also recommended that the flexible cable of the keypad be removed.

Return the instrument to Brauniger for a readjustment and a final check over.

**The guarantee is void after a Water Landing.**

## 12 Guarantee and liability

Our instruments carry a 24-month guarantee. However, physical damage such as a broken casing or glass breakage as well as damage resulting from water landings are excluded from this guarantee. Brauniger GmbH can accept no liability for faults arising from any abuse or unapproved use of your instruments.

### WARNING

In very rare cases it can happen that a flight instrument does not provide any data at all or the data is incorrect. Brauniger will not be held responsible for accepting any damage claims arising from a malfunctioning unit. Responsibility for ensuring the safe execution of his/her flights lies with the pilot alone.